

✓ **Applications**

Range of Dead weight tester is designed to test, adjust and calibrate measuring instruments, mechanical or electronic pressure by comparison (pressure gauges, pressure transmitters or sensors or switches)

They consist of a pressure generator, a piston/cylinder unit, a set of weigh identified and of a computer on which is posted : the position of the piston and the value of pressure generated by the dead weight according to the various physical quantities.

The capstan is used to generate a pressure pushing the fluid through the piston. This pressure is balanced by the piston/cylinder assembly which allows to compare the instrument to be calibrated to the pressure values generated by the standard. These scales are intended for the calibration gauge.

The Dead weight are robust and easy to use and have a high long-term stability.

✓ **Technical specifications**

- **Calibration :** It is necessary to recalculate the pressure generated by the dead weight according to the different variables. Our dead weight are calibrated in the following terms of use :
Temperature 20°C - Pressure atmos. 1013.25 hPa - Humidity 50% - acceleration 9.80665 m/s²
- **Fluid :** Mineral or synthetic oil depending on model, colorless, compatible with medical or food uses – tank volume 125 cm³
- **Check/adjust the seat :** leveling bubble and adjustable feet
- **Connection for the instrument to be tested :** swivel G1/2 standard
- **Motorization :** training the weight in rotation by electric engine
- **Measure of the temperature :** Precision ± 0.1°C
- **Measure of the atmospheric pressure :** Precision ± 1HPa
- **Measure of the hygrometry :** Precision ± 10%
- **Calculator :**
 - with dynamic display of the position of the piston
 - with automatic display of the pressure generated by the dead weight according to the temperature, the atmospheric pressure and the hygrometry
 - with a connection for the transfer of the data on computer, allowing a total traceability
- **Carter :** Light alloy aluminium AG3 + high-resistance paint
- **Ratchet :** removable for transport
- **Piston/cylinder :** Single piston treated stainless - **Répeatability** : 2.10⁻⁵ -
- **Sensitivity** : 1.10⁻⁵ - **Precision dead weight** : 8.10⁻⁵
- **Weight :** stainless steel - **Weight** of the set of weights from 25 kg to 100 kg depending on model – Shape masses ergonomic, easy loading of the masses on the bell - **Marking** corresponding with the measuring unit (bar, mbar, KPa, PSI etc..)

✓ **Specific Model**

- **Model :** BH4-5000B - Dead weight tester single piston
- **Measuring range :** 40 to 5000 bar / 600 to 72000 PSI / 4000 to 500000 kPa
- **Accuracy dead weight:** $8 \cdot 10^{-5} \times P$ (with P in bar)
- **Weight dead weight without masses :** 22 kg
- **Fluid :** Oil Sebacate - fluid density : 915 kg/m³
- **Typical cross-section of the piston :** 1.96315 mm²
- **Material piston/cylinder :** tungsten carbide
- **Number of piston :** 1

✓ **Divers**

- **Manuel :** a detailed operating instructions supplied with the device + Certificate + 0.5 liter Oil
- **Maintenance :** Our technical department is at your disposition for the revision, calibration or service your unit – Calibration device recommended every 2 years.

✓ **Dimensions of device**

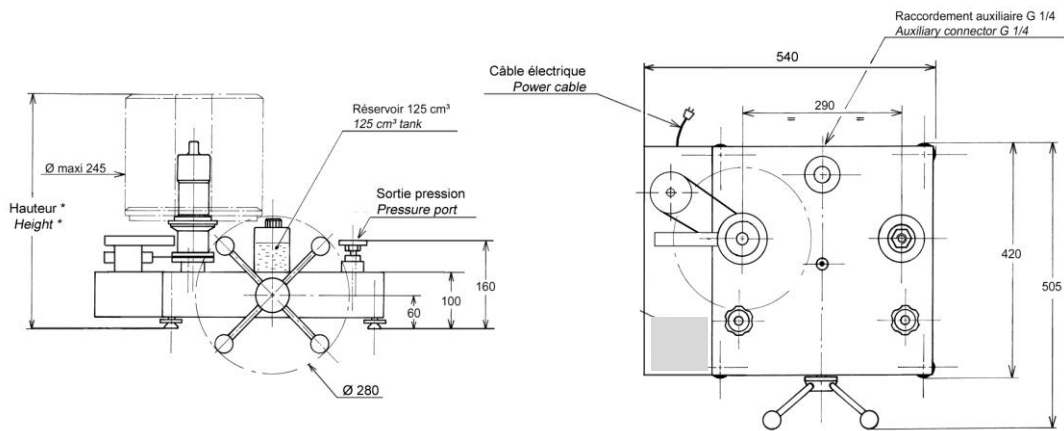

Height with standard set of weight : (bar, kPa) : 570 mm (PSI) : 540 mm

Unit used : mm

✓ **Standard weight sets** (for other units contact us)

Standard set			
	Pressure (bar)	Total weight	Typical value (g)
Unit : BAR (Ref. MB0060)	400	10	8000
	360	1	7200
	200	2	4000
	80	2	1600
	40	1	800
	20	1	400
	10	1	200
	8	1	160
	4	1	80
	2	1	40
Initial pressure bell	40		800
TOTAL	5004	21	± 100 kg

Optional :

- Set of weights adjustment from 1 mg to 50g with COFRAC certificat (Ref.OP237-200)
- COFRAC or DAkKS certificat confirming the accuracy until $5 \cdot 10^{-5}$

Standard set			
	Pressure (PSI)	Total weight	Typical value (g)
Unit : PSI (Ref. MB0000)	4000	16	5520
	3400	1	4968
	2000	1	2760
	800	2	1104
	400	1	552
	200	1	276
	80	2	110.4
	40	1	55.2
	20	1	27.6
	Initial pressure bell	600	
TOTAL	71820	26	± 99 kg

Standard set			
Unit : kPa	Pressure (kPa)	Total weight	Typical value (g)
	40000	10	8000
	36000	1	7200
	20000	2	4000
	8000	2	1600
	4000	1	800
	2000	1	400
	1000	1	200
	800	1	160
	400	1	80
	200	1	16
	Initial pressure bell	4000	
TOTAL	500400	21	± 100 kg

✓ **Options for weight set**



transport metal boxes

(OP0101) : 260 x 260 x 310 mm - weight empty : 6 kg



Suitcase for post planning and transportation

(OP0095) small : 280 x 250 x 280 mm weight empty : 5 kg

(OP0099) large : 500 x 350 x 280 mm - weight empty : 11 kg

Useful for BH4-5000B : Consult us (depending on the unit)

✓ **Options**

- Standard weight set additional for different units
- Adjust the dead weight with a different acceleration of 9.80665 m/s² on request
- Calibration of the instrument : Points statement AREMECA or certificate of calibration DAkKs or COFRAC
- Tin oil : 1 liter, 2 liters or 5 liters of oil

✓ **Transport and packaging**

- **Packaging** : woodpack is provided for the shipping

Designation/Reference	Dimension / carton or shipping crate	Weight empty / total weight (packaging + materiel)
Dead weight without weight	470 x 470 x 240 mm	Carton empty 1.5 kg Total weight ±24 kg
Standard weight set	300 x 300 x 170 mm	Carton empty 1.5 kg Total weight ±102 kg
Wood packaging SB0003	980 x 700 x 400 mm	Suitcase empty 20 kg Total weight ±126 kg (dead weight + weight set + packaging)



SB0003

- **Note** : shipping is extra.

✓ **Other models available in the range BH4**

(Datasheet is available on request)

Models single piston

Models	Accuracy	Measuring range		
		Bar or kg/cm ²	PSI	kPa
BH4-4000B	10 ⁻⁵	40 to 4000	600 to 60000	4000 to 400000
BH4-3000B	10 ⁻⁵	40 to 3000	600 to 44000	4000 to 300000
BH4-2500B	10 ⁻⁵	40 to 2500	600 to 36200	4000 to 250000
BH4-2000B	10 ⁻⁵	40 to 2000	600 to 30000	4000 to 200000
BH4-1200B sp	10 ⁻⁵	2 to 1200	30 to 16000	200 to 120000
BH4-600B sp	10 ⁻⁵	2 to 600	30 to 10000	200 to 60000
BH4-300B sp	10 ⁻⁵	1 to 300	15 to 4000	100 to 30000
BH4-120B	10 ⁻⁵	0.5 to 120	10 to 1740	50 to 12000
BH4-60B	10 ⁻⁵	0.2 to 60	3 to 800	20 to 6000
BH4-30B	10 ⁻⁵	1 to 30	10 to 400	100 to 3000

✓ **Accessories** (Ask for our specific documentation)

- Accessory case (ref.OP0057)
- Setting gauge kit (ref.OP0125)
- Case connectors M (ref.OP0174) – Case connectors G (ref.OP0171) - Case connectors NPT (ref.OP0172) - Case connectors BSP-TR (ref.OP0173) - Case with 17 connectors M + G + NPT + BSP-TR (ref.OP0037) – unit connector (consult us)
- Kit drain tank (ref.OP0025)
- Bench cleaning (ref.OP0062)
- Carrying case (ref.OP0002)