



✓ **Applications**

Range of Dead weight tester is designed to test, adjust and calibrate measuring instruments, mechanical or electronic pressure by comparison (pressure gauges, pressure transmitters or sensors or switches)

They consist of a pressure generator, a piston/cylinder unit, a set of weigh identified. The capstan is used to generate a pressure pushing the fluid through the piston. This pressure is balanced by the piston/cylinder assembly which allows to compare the instrument to be calibrated to the pressure values generated by the standard. These scales are intended for the calibration gauge.

The Dead weight are robust and easy to use and have a high long-term stability.

✓ **Technical specifications**

- Calibration :	It is necessary to recalculate the pressure generated by the dead weight according to the different variables. Our dead weight are calibrated in the following terms of use : Temperature 20°C - Pressure atmos. 1013.25 hPa - Humidity 50% - acceleration 9.80665 m/s ²
- Fluid :	Mineral or synthetic oil depending on model, colorless, compatible with medical or food uses – tank volume 125 cm ³
- Check/adjust the seat :	leveling bubble and adjustable feet
- Connection for the instrument to be tested :	swivel G1/2 standard
- Rotating weigh :	Training masses : manual rotation
- Carter :	Light alloy aluminium AG3 + high-resistance paint
- Ratchet :	removable for transport
- Piston/cylinder :	Single or twin piston tungsten carbide and/or treated steel - Repeatability : 3.10 ⁻⁵ - Sensitivity : 1.10 ⁻⁵ - Precision dead weight : 10 ⁻⁴
- Weight :	stainless steel - Weight of the set of weights from 25 kg to 100 kg depending on model – Shape masses ergonomic, easy loading of the masses on the bell - Marking corresponding with the measuring unit (bar, mbar, KPa, PSI etc..)

✓ **Specific Model**

- Model :	BH2-700B sp - dead weight single piston
- Measuring range :	2 to 700 bar / 30 to 10000 PSI / 200 to 70000 kPa
- Accuracy dead weight:	0.002 + (1.10 ⁻⁴ x P) (with P in bar)
- Weight dead weight without masses :	18 kg
- Fluid :	Oil H40 - fluid density : 860 kg/m ³
- Typical cross-section of the piston :	3.92450 mm ²
- Material piston/cylinder :	tungsten carbide
- Number of piston :	1

✓ **Divers**

- **Manuel** : a detailed operating instructions supplied with the device + Certificate + 0.5 liter Oil
- **Maintenance** : Our technical department is at your disposition for the revision, calibration or service your unit – Calibration device recommended every 2 years.

✓ **Dimensions of device**

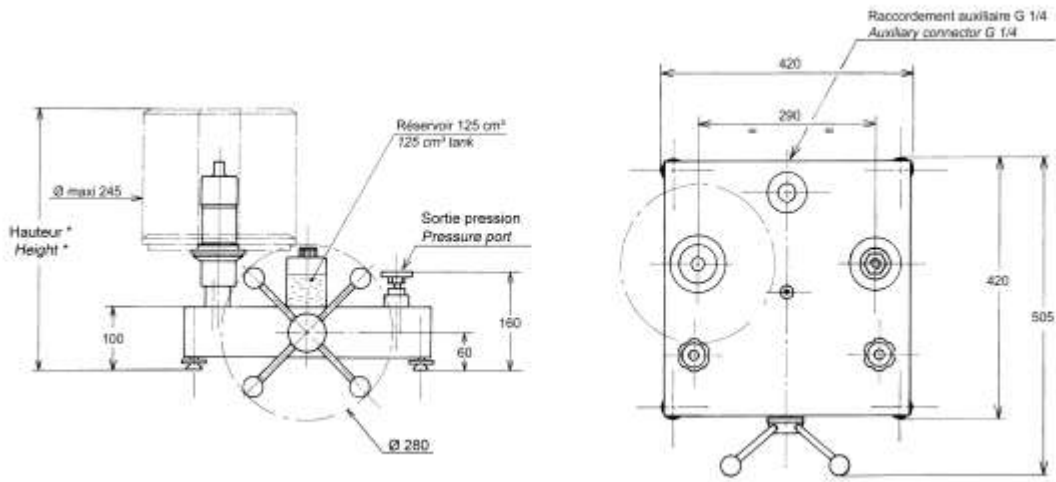

Height with standard set of weight : (bar) : 340 mm (PSI) : 350 mm

Unit used : mm

✓ **Standard weight sets and intermediate**

Standard set			
	Pressure (bar)	Total weight	Typical value (g)
Unit : BAR (Ref. MB0024) + masse 100 bar	200	1	8000
	180	1	7200
	100	2	4000
	40	2	1600
	20	1	800
	10	1	400
	4	2	160
	2	1	80
	1	1	40
	Great initial pressure bell	20	x
Initial pressure	2	x	80
Small bell + weight adaptation			
TOTAL	723	12	±25 kg

Intermediate set			
	Pressure (bar)	Total weight	Typical value (g)
BAR (Ref. MB0025)	0.4	2	16
	0.2	1	8
	0.1	1	4
	0.05	1	2
TOTAL	1.15	5	46 g

Standard set			
	Pressure (PSI)	Total weight	Typical value (g)
Unit : PSI (Ref. MB0027)	2000	3	5520
	1800	1	4968
	1000	1	2760
	400	2	1104
	200	1	552
	100	1	276
	40	2	110.4
	20	1	55.2
	10	1	27.6
	Great initial pressure bell	200	x
Initial pressure	30	x	83
Small bell + weight adaptation			
TOTAL	10240	13	±29 kg

Intermediate set			
	Pressure (PSI)	Total weight	Typical value (g)
PSI (Ref. MB0029)	4	2	11
	2	1	5.5
	1	1	2.75
	0.5	1	1.25
TOTAL	11.5	5	31.5 g

Standard set			
	Pressure (Kpa)	Total weight	Typical value (g)
Unit : kPa	20000	1	8000
	18000	1	7200
	10000	1	4000
	4000	2	1600
	2000	1	800
	1000	1	400
	400	2	160
	200	1	80
	100	1	40
	Great initial pressure bell	2000	x
Initial pressure	200	x	80
Small bell + weight adaptation			
TOTAL	62300	11	±25 kg

Intermediate set			
	Pressure (Kpa)	Total weight	Typical value (g)
kPa	40	2	16
	20	1	8
	10	1	4
	5	1	2
TOTAL	115	5	46 g

✓ **Options for weight set**



transport metal boxes

(OP0101) : 260 x 260 x 310 mm - weight empty : 6 kg

Suitcase for post planning and transportation

(OP0100) small : 280 x 250 x 280 mm - weight empty : 5 kg

(OP0099) large : 500 x 350 x 280 mm - weight empty : 11 kg

Useful for BH2-600B sp : Consult us !

✓ **Options**

- Intermediate weight set or Standard weight set additional for different units
- Adjust the dead weight with a different acceleration of 9.80665 m/s^2 on request
- Calibration of the instrument : Points statement AREMECA or certificate of calibration DAkKS or COFRAC
- Tin oil : 1 liter, 2 liters or 5 liters of oil
- Motorization kit / visualization

✓ **Transport and packaging**

- **Packaging** : woodpack is provided for the shipping

Designation/Reference	Dimension / carton or shipping crate	Weight empty / total weight (packaging + materiel)
Dead weight without weight	470 x 470 x 240 mm	Carton empty 1.5 kg Total weight ± 20 kg
Standard weight set	300 x 300 x 170 mm	Carton empty 1.5 kg Total weight ± 28 kg
Wood packaging SB0002	790 x 480 x 340 mm	Suitcase empty 20 kg Total weight ± 70 kg (dead weight + weight set + packaging)



SB0002

- **Note** : shipping is extra.

✓ **Other models available in the range BH2**

(Datasheet is available on request)

Models single piston

Models	Accuracy	Measuring range		
		Bar ou kg/cm^2	PSI	kPa
BH2-5000B	10^{-4}	40 to 5000	600 to 72500	4000 to 500000
BH2-4000B	10^{-4}	40 to 4000	600 to 60000	4000 to 400000
BH2-3000B	10^{-4}	40 to 3000	600 to 44000	4000 to 300000
BH2-2500B	10^{-4}	40 to 2500	600 to 36200	4000 to 250000
BH2-2000B	10^{-4}	40 to 2000	600 to 30000	4000 to 200000
BH2-1200B sp	10^{-4}	2 to 1200	30 to 16000	200 to 120000
BH2-300B sp	10^{-4}	1 to 300	15 to 4000	100 to 30000
BH2-150B	10^{-4}	0.5 to 150	10 to 2000	50 to 15000
BH2-60B	10^{-4}	0.2 to 60	3 to 800	20 to 6000
BH2-30B	10^{-4}	0.1 to 30	2 to 400	10 to 3000

Dual piston models : these dead weight tester integrating two pistons can get two ranges from a single set of weight

Models	Accuracy	Measuring range		
		Bar ou kg/cm^2	PSI	kPa
BH2-1200B dp	10^{-4}	1 to 60 + 20 to 1200	10 to 800 + 200 to 16000	100 to 6000 2000 to 120000
BH2-600B dp	10^{-4}	1 to 60 + 10 to 600	10 to 800 + 100 to 8000	100 to 6000 1000 to 60000
BH2-300B dp	10^{-4}	1 to 60 + 5 to 300	10 to 800 + 50 to 4000	100 to 6000 500 to 30000

✓ **Accessories** (Ask for our specific documentation)

- Accessory case (ref.OP0057)
- Setting gauge kit (ref.OP0125)
- Separator all fluids up to 800 bar (ref.OP0023)
- Case connectors M (ref.OP0174) – Case connectors G (ref.OP0171) - Case connectors NPT (ref.OP0172) - Case connectors BSP-TR (ref.OP0173) - Case with 17 connectors M + G + NPT + BSP-TR (ref.OP0037) – unit connector (consult us)
- Kit drain tank (ref.OP0025)
- Bench cleaning (ref.OP0062)
- Carrying case (ref.OP0002)