

✓ **Applications**

Range of Dead weight tester is designed to test, adjust and calibrate measuring instruments, mechanical or electronic pressure by comparison (pressure gauges, pressure transmitters or sensors or switches)

They are constituted by a generator of pressure, connected to a compressed source of air, a unity piston/cylinder, of a set of weight identified and of a computer on which is posted : the position of the piston and the value of pressure generated by the dead weight according to the various physical quantities.

The capstan allows to adjust the pressure by compressing the gas through the piston. This pressure is balanced by the set piston/cylinder what allows to compare the instrument to be calibrated in the values of pressures generated by the standard and indicated on the calculator. These dead weight are intended for the calibration in relative pressure.

The Dead weight are robust and easy to use and have a high long-term stability.

✓ **Technical specifications**

- **Calibration :** It is necessary to recalculate the pressure generated by the dead weight according to the different variables. Our dead weight are calibrated in the following terms of use :
Temperature 20°C - Pressure atmos. 1013.25 hPa - Humidity 50% - acceleration 9.80665 m/s²
- **Fluid :** The system of automatic lubrication integrated into the dead weight avoids the risks of contamination piston/cylinder. Colorless, compatible mineral oil with medical or food uses - volume of the reservoir 20 cm³
- **Source Pressure :** Dry air - gas connection ¼ cylindrical female - This balance needs to be connected to a pressure source.
- **Check/adjust the seat :** leveling bubble and adjustable feet
- **Connection for the instrument to be tested :** swivel G1/2 standard
- **Motorization :** training the weight in rotation by electric engine
- **Measure of the temperature :** Precision ± 0.1°C
- **Measure of the atmospheric pressure :** Precision ± 1hPa
- **Measure of the hygrometry :** Precision ± 10%
- **Calculator :**
 - with dynamic display of the position of the piston
 - with automatic display of the pressure generated by the dead weight according to the temperature, the atmospheric pressure and the hygrometry
 - with a connection for the transfer of the data on computer, allowing a total traceability
- **Carter :** Light alloy aluminium AG3 + high-resistance paint
- **Ratchet :** removable for transport
- **Piston/cylinder :** Single piston treated stainless - **Repeatability** : 1.10⁻⁵ - **Sensitivity** : 0,5.10⁻⁵ - **Precision dead weight** : 5.10⁻⁵
- **Weight :** corrosion treated steel - **Weight** of the set of weights from 33 kg to 48 kg depending on model - Shape masses ergonomic, easy loading of the masses on the bell - **Marking** corresponding with the measuring unit (bar, mbar, KPa, PSI etc..)

✓ **Specific Model**

- **Model :** BA4-200B - dead weight simple piston
- **Measuring range :** 2.5 to 200 bar / 25 to 3000 PSI / 250 to 20000 kPa
- **Accuracy dead weight :** $0.001 + (0.5 \cdot 10^{-4} \times P)$ (with P en bar)
- **Weight dead weight without weight :** 22 kg
- **Typical cross-section of the piston :** 15.6966 mm²
- **Material piston/cylinder :** stainless steel
- **Number of piston :** 1

✓ **Various**

- **Manuel :** a detailed operating instructions supplied with the device + Certificate + 0.5 liter oil
- **Maintenance :** Our technical department is at your disposition for the revision, calibration or service your unit – Calibration device recommended every 2 years

✓ **Dimensions of device**

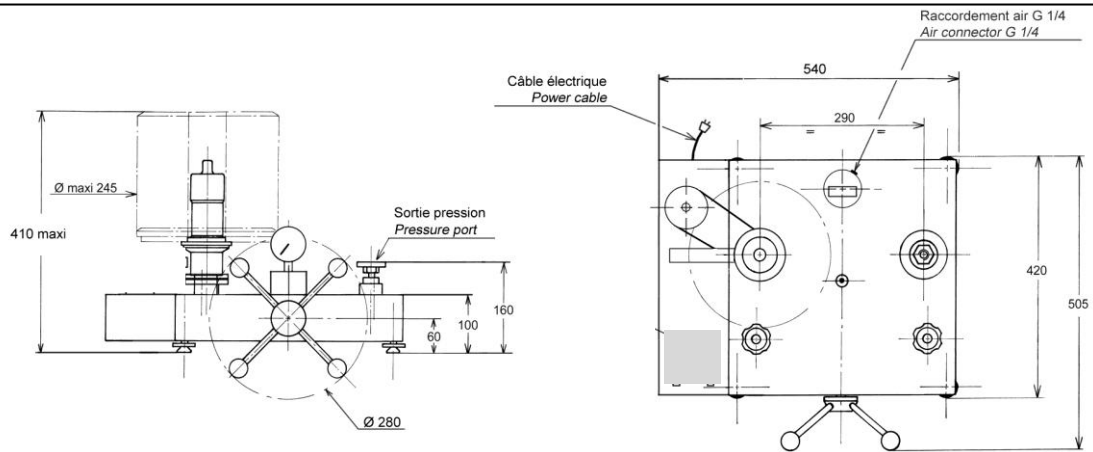

Height with standard set of weight : (bar, kPa) : 395 mm (PSI) : 379 mm

Unit used : mm

✓ **Standard weight sets and intermediate** (for other units contact us)

Standard set			
	Pressure (bar)	Total weight	Typical value (g)
Unit : BAR (Ref. MB0031)	50	2	8000
	47.5	1	7600
	25	1	4000
	10	2	1600
	5	1	800
	2.5	1	400
	1	2	160
	0.5	1	80
Initial Pressure bell + weight adaptation	2.5		400
TOTAL	205	11	±33 kg

Intermediate set			
	Pressure (bar)	Total weight	Typical value (g)
BAR (Ref. MB0032)	0.25	1	40
	0.1	2	16
	0.05	1	8
	0.02	2	3.2
	0.01	1	1.6
	TOTAL	0.43	7

Standard set			
	Pressure (PSI)	Total weight	Typical value (g)
Unit : PSI	500	4	5520
	475	1	5244
	250	1	2760
	100	2	1104
	50	1	552
	25	1	276
	10	2	110.4
	5	1	55.2
Initial Pressure bell	25		276
TOTAL	3050	13	±34 kg

Intermediate set			
	Pressure (PSI)	Total weight	Typical value (g)
PSI	2.5	1	27.6
	1	2	11
	0.5	1	5.5
	0.2	2	2.2
	0.1	1	1.1
	TOTAL	5.5	7

Standard set			
Unit : kPa	Pressure (Kpa)	Total weight	Typical value (g)
	5000	2	8000
	4750	1	7600
	2500	1	4000
	1000	2	1600
	500	1	800
	250	1	400
	100	2	160
	50	1	80
	Initial Pressure bell + weight adaptation	250	
TOTAL	20500	11	±33 kg

Intermediate set			
kPa	Pressure (Kpa)	Total weight	Typical value (g)
	25	1	40
	10	2	16
	5	1	8
	2	2	3.2
	1	1	1.6
TOTAL	43	7	88 g

✓ **Options for weight set**

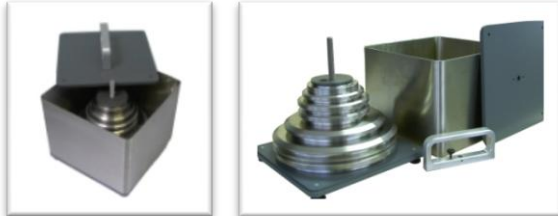

transport metal boxes

(OP0101) : 260 x 260 x 310 mm - weight empty : 6 kg



Suitcase for post planning and shipping

(OP0095) small : 280 x 250 x 280 mm - weight empty : 5 kg
(OP0099) large : 500 x 350 x 280 mm - weight empty : 11 kg

Useful for BA4-200B : Consult us !

✓ **Options**

- Weight set additional base for different units
- Adjust the dead weight with a different acceleration of 9.80665 m/s² on request
- Calibration of the instrument : Points statement AREMECA or certificate of calibration DAkkS or COFRAC
- Degreasing oxygenates optional (consult us)

✓ **Shipping and packaging**

- **Packaging** : woodpack is provided for the shipping

Designation/Reference	Dimension / carton or shipping crate	Weight empty / total weight (packaging + materiel)
Dead weight without weight	470 x 470 x 240 mm	Carton empty 1.5 kg Total weight ±24 kg
Standard weight set	300 x 300 x 170 mm	Carton empty 1.5 kg Total weight ± 35 kg
Wood packaging SB0003	980 x 700 x 400 mm	Suitcase empty 20 kg Total weight ± 79 kg (dead weight + weight set + packaging)



SB0003

- **Note** : shipping is extra.

✓ **Other models available in the range BA4**

(Datasheet is available on request)

Models simple piston

Models	Accuracy	Measuring range		
		Bar ou kg/cm ²	PSI	kPa
BA4-120B	10 ⁻⁴	1 to 120	10 to 1600	100 to 12000
BA4-60B	10 ⁻⁴	0.5 to 60	5 to 800	50 to 6000

✓ **Accessories** (Ask for our specific documentation)

- Accessory case (ref.OP0057)
- Setting gauge kit (ref.OP0125)
- Case connectors M (ref.OP0174) – Case connectors G (ref.OP0171) - Case connectors NPT (ref.OP0172) - Case connectors BSP-TR (ref.OP0173) - Case with 17 connectors M + G + NPT + BSP-TR (ref.OP0037) – unit connector (consult us)
- Carrying case for dead weight (ref.OP0002)